

COMPRESSEUR HYDRAULIQUE



Compresseur hydraulique

- Tension moteur : 12-24V
- Cylindrée compresseur : 145cc
- Réfrigérant compresseur: R134a
- Type de raccord O-Ring
- Lubrifiant compresseur : PAG56
- Charge d'huile initiale compresseur : 160 cc
- Vanne de commande hydraulique non fournie

Hydraulic compressor

- Motor Voltage: 12-24V
- Compressor displacement: 145cc
- Compressor R134a coupler ports
- O-Ring fitting type
- Compressor lubricant : PAG56
- Compressor initial oil charge : 160 cc
- Hydraulic command valve not supplied



visuel non contractuel

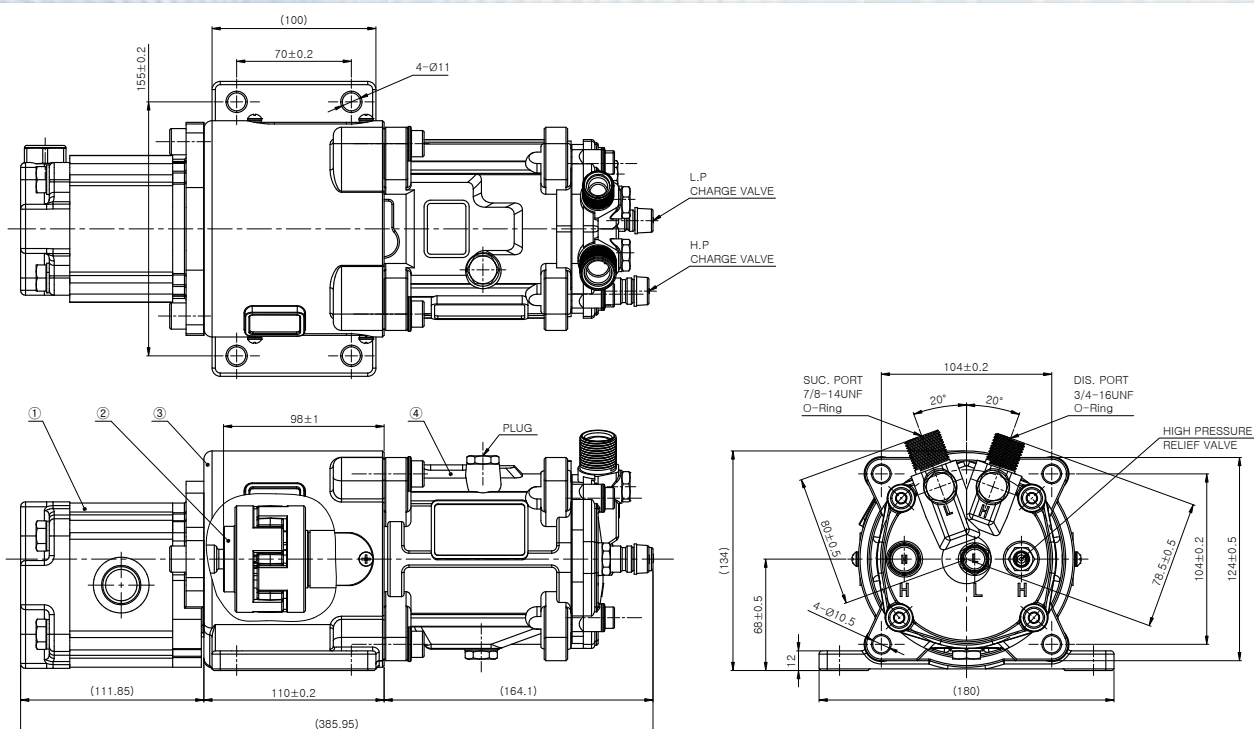

Type Type	Référence / Reference	
	12 V	24 V
COMPRESSEUR HYDRAULIQUE 14cc / 14cc HYDRAULIC COMPRESSOR	0400 1201	0400 1202

Type Type	Référence Reference	Tension moteur Motor voltage	Pression Max. Moteur Motor Max. Pressure	Cylindrée Capacity	Tours par minute max. Max. RPM
UPH150	0400 1201	12V	2500 bars	160cc (compressor) 14cc (hydraulic motor)	6000 RPM (compressor) 2500 RPM (hydraulic motor)
UPH150	0400 1202	24V			